

THE FLUORACTOR[®] Y1112L FLUORESCENT LAMP STARTER SWITCH

Copyright © 1998, Power Innovations Limited, UK

MARCH 1998 - REVISED MAY 1998

- $V_{(BR)}$ 1200 to 1500 V
- $I_H > 175$ mA
- $I_{GT} < 2$ mA

description

This product is intended for use as a T8/T12 fluorescent tube starter switch on 200-240 V a.c. supplies with tube sizes up to 5 ft with leading and lagging ballast circuits.

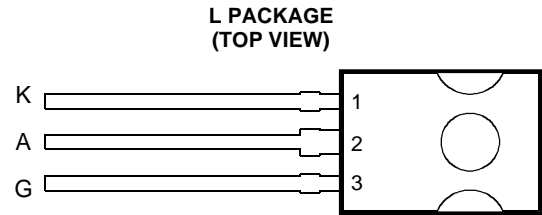

Pin 2 is in electrical contact with the heat slug.

MDXXAO

absolute maximum ratings at 25°C case temperature (unless otherwise noted)

RATING	SYMBOL	VALUE	UNIT
Crest working off-state voltage (Full wave rectified 50 Hz a.c.)	V_{DWM}	375	V
Peak reverse gate voltage	V_{RGM}	6	V
On-state current	I_T	1.5	A
— continuous	I_{TRM}	2	
— repetitive peak	I_{TSM}	10	
— non-repetitive peak			
Peak gate current	I_{GRM}	0.5	A
Average gate power	$P_{G(av)}$	0.3	W
Operating case temperature range	T_C	-5 to +85	°C
Storage temperature range	T_{stg}	-10 to +110	°C
Lead temperature during soldering 1.6 mm from the case for 10 seconds	T_{lead}	230	°C

electrical characteristics at 25°C case temperature (unless otherwise noted)

PARAMETER	TEST CONDITIONS	MIN	TYP	MAX	UNIT
I_D Off-state current	$V_D = V_{DWM}$ $T_j = 65^\circ\text{C}$			1	mA
V_T On-state voltage	$I_T = 2$ A			3.1	V
$V_{(BR)}$ Clamping voltage	$I_{(BR)} = 5$ mA $t_p < 200$ μs , 2% duty cycle	1200		1500	V
I_H Holding current	See application circuit	175			mA
I_{GTM} Peak gate trigger current	$V_{AA} = 10$ V $R_L = 10$ Ω			2	mA
V_{GTM} Peak gate trigger voltage	$V_{AA} = 10$ V $R_L = 10$ Ω			3	V

Fluoractor[®] is a Registered Trade Mark of Power Innovations Ltd

PRODUCT INFORMATION

Information is current as of publication date. Products conform to specifications in accordance with the terms of Power Innovations standard warranty. Production processing does not necessarily include testing of all parameters.



THE FLUORACTOR[®] Y1112L FLUORESCENT LAMP STARTER SWITCH

MARCH 1998 - REVISED MAY 1998

applications data

The conventional method of starting fluorescent tubes employs the use of an electromechanical canister. This consists of a bimetallic strip which opens as it cools and in conjunction with the ballast inductor, provides the tube striking voltage. However, the random nature of the pulsing results in repeated striking attempts and degradation of both the tube and starter. The tube degradation is illustrated by its progressively blackening ends and ultimately required tube replacement.

The Y1112L, "Fluoractor[®]", has been specifically introduced for use in electronic starters. This unique device offers the lighting industry an opportunity to develop electronic starters small enough to be retrofit replacements for the established electromechanical canisters. Its double thyristor structure with integrated zener clamp diode and current mirror provides the technology for a starter with enhanced features such as controlled flicker free start up, automatic tube shutdown at end of tube life and reduced degradation of tube ends leading to extended life. The increased functionality, lifetime and reliability of these starters has led in some cases to them being embodied in the ballast itself, a development not feasible with the old electromechanical canisters.

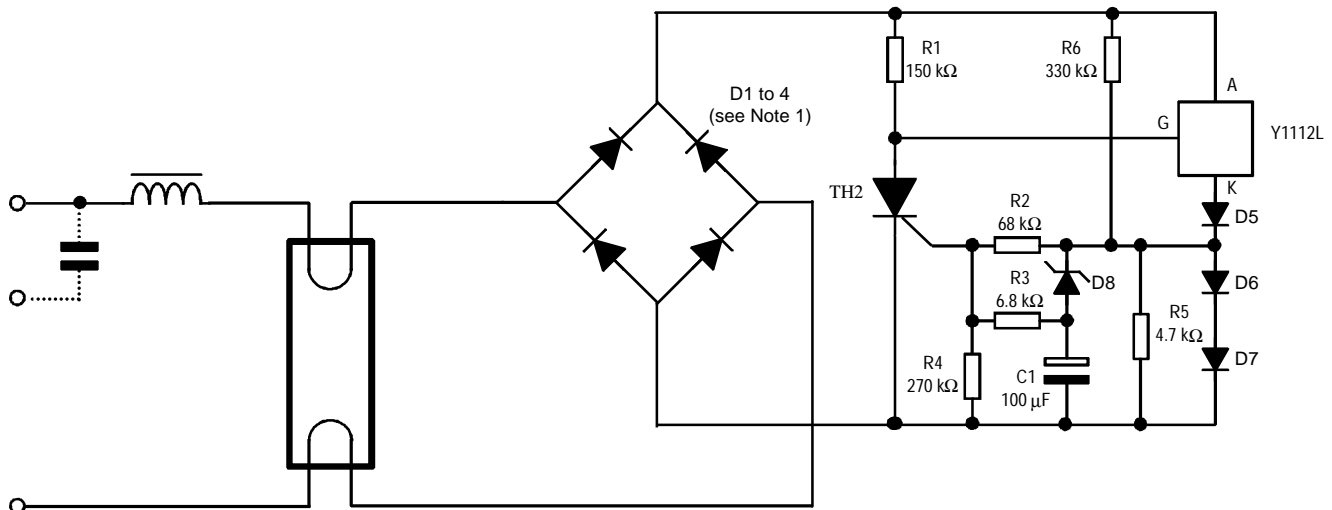

Figure 1. Two terminal starter circuit

NOTE 1: These rectifiers need to be voltage selected for $V_R \geq V_{(BR)max} + 150 V$

MECHANICAL DATA

SOT-82

3-pin plastic single-in-line package

This single-in-line package consists of a circuit mounted on a lead frame and encapsulated within a plastic compound. The compound will withstand soldering temperature with no deformation, and circuit performance characteristics will remain stable when operated in high humidity conditions. Leads require no additional cleaning or processing when used in soldered assembly.

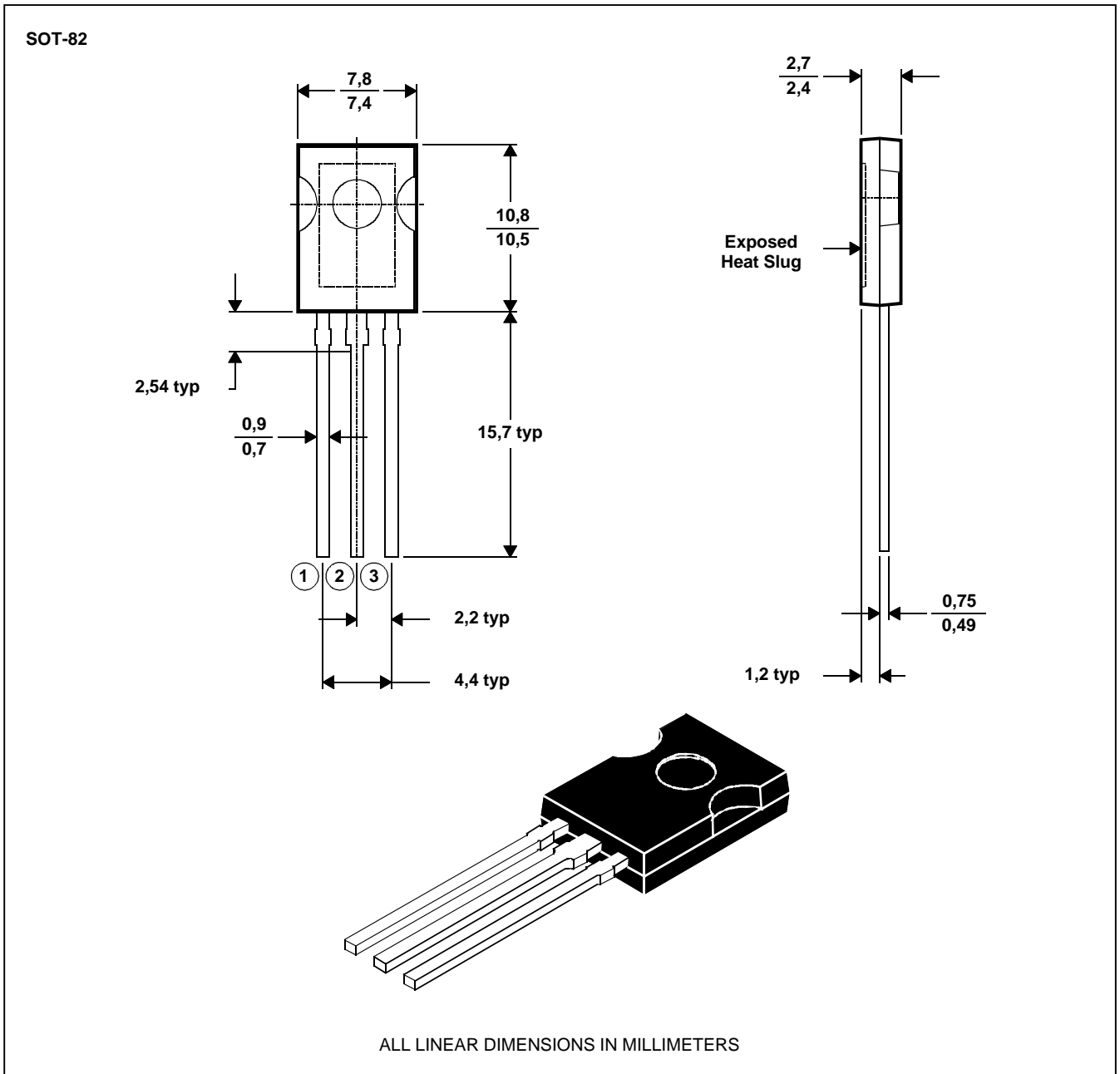

NOTE: The centre pin is in electrical contact with the heat slug.

MDXXAQ

THE FLUORACTOR[®] Y1112L FLUORESCENT LAMP STARTER SWITCH

MARCH 1998 - REVISED MAY 1998

IMPORTANT NOTICE

Power Innovations Limited (PI) reserves the right to make changes to its products or to discontinue any semiconductor product or service without notice, and advises its customers to verify, before placing orders, that the information being relied on is current.

PI warrants performance of its semiconductor products to the specifications applicable at the time of sale in accordance with PI's standard warranty. Testing and other quality control techniques are utilized to the extent PI deems necessary to support this warranty. Specific testing of all parameters of each device is not necessarily performed, except as mandated by government requirements.

PI accepts no liability for applications assistance, customer product design, software performance, or infringement of patents or services described herein. Nor is any license, either express or implied, granted under any patent right, copyright, design right, or other intellectual property right of PI covering or relating to any combination, machine, or process in which such semiconductor products or services might be or are used.

PI SEMICONDUCTOR PRODUCTS ARE NOT DESIGNED, INTENDED, AUTHORIZED, OR WARRANTED TO BE SUITABLE FOR USE IN LIFE-SUPPORT APPLICATIONS, DEVICES OR SYSTEMS.

Copyright © 1998, Power Innovations Limited

PRODUCT INFORMATION